



FALCONBOARD™

THE ENVIRONMENTALLY-RESPONSIBLE DISPLAY BOARD ALTERNATIVE

Hexacomb® Falconboard is the only graphic display board made from reusable, renewable and 100% recyclable kraft paper honeycomb material. An extension of our signature Hexacomb honeycomb line of custom and quality products, Falconboard offers designers and fabricators a truly recyclable, environmentally-conscious product that helps divert millions of pounds of waste from land fills.

Falconboard consists of SFI* certified fabricated natural kraft core with white clay-coated or natural linerboard facings. Produced with up to 20% recycled paper content which is chlorofluorocarbon-free, Falconboard emits zero volatile organic compounds (VOCs) and is an excellent "green" alternative to traditional foam boards made from polyethylene (PE), polystyrene (PS) or polyvinylchloride (PVC). Printing capabilities equal that of foamboards, including multiple wide format and digital solutions. Its unique structure can handle the most demanding of applications in the graphic display market due to its high rigidity and dimensional stability.

Key Features and Benefits	Results
<p>SUSTAINABILITY</p> <ul style="list-style-type: none"> Made with SFI certified all natural, renewable virgin and post-consumer recycled fibers to provide optimal strength and printing performance 100% recyclable Renewable and reusable Zero chlorofluorocarbons Uses up to 20% recycled paper content 	<ul style="list-style-type: none"> Promotes closed loop recycling Lessens dependence on petroleum based resins Lessens landfill waste Increases corporate environmental responsibility and stewardship
<p>PERFORMANCE</p> <ul style="list-style-type: none"> High rigidity and dimensional stability Lightweight Dry and cold mountable Heat resistant to 300° Fahrenheit Superior beam and compression strength Excellent printability 	<ul style="list-style-type: none"> Tough core resists denting Cuts easily and cleanly Perfect for die-cutting Great for demanding mounting applications Durable - scratch and warp resistant No additional backing required
<p>VERSATILITY</p> <ul style="list-style-type: none"> Custom sizes available Works well with most inks and adhesives Works with most commercial connective systems such as edge tap and plastic or metal edging or channels Board can be reused by painting or cutting into new shapes Does not require any special tools for shaping 	<ul style="list-style-type: none"> Well-suited for a diverse range of applications and fabrication Aesthetically pleasing appearance Easy-to-use and store Use and reuse for multiple functions



THINK SUSTAINABILITY, THINK PREGIS

With an ongoing commitment to develop industry leading products and technologies that limit harm to the environment, Falconboard is an addition to the Pregis "green" family of products whose purpose is addressing the growing need for sustainable packaging alternatives. Environmentally responsible practices are an important part of Pregis' business philosophy.

*SFI is the Sustainable Forestry Initiative, a fully independent, charitable organization dedicated to promoting sustainable forest management. Their certification standard is based on principles that promote sustainable forest management, including measures to protect water quality, biodiversity, wildlife habitat, species at risk, and forests with exceptional conservation value.

AN EXTRAORDINARY SOLUTION FOR YOUR SPECIFIC APPLICATION OR FABRICATION NEED



Applications	Point-of-purchase (POP) displays, interior signage, exhibits, kiosks, framing, mounting, specialty print market, direct digital printing, direct screen printing, painting, retail market
Fabrication	Knife/blade cutting, die-cutting, saw cutting (table saw, band saw, scroll saw), computerized cutting tables

FALCONBOARD is easy to cut, slit, and form into many shapes and custom sizes utilizing most common hand held cutting knife blades. Computerized cutting tables that are commonly used throughout the corrugated industry can easily cut / slit Falconboard for any custom application. Falconboard is clean and easy to work with compared to plywood or foam products. Sawdust, nails, splinters and disposal problems are eliminated.

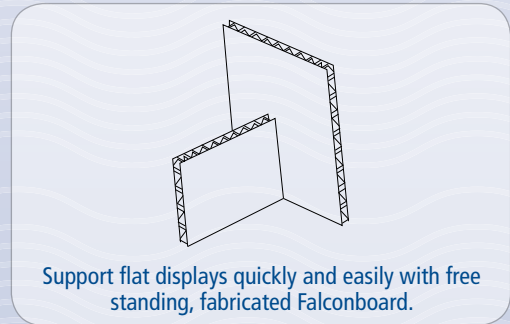
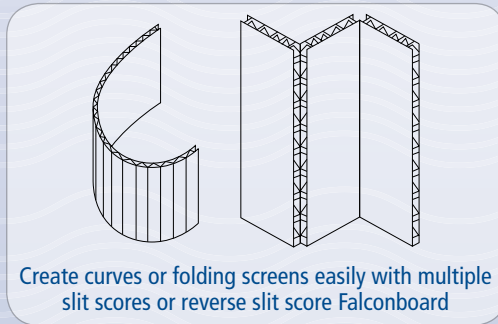

Standard thickness	1/4", 3/8", 1/2", 3/4", 1", 1 1/2", 2" through 4"
Standard sheet size	48"x96", 48"x120", 60"x96", 60"x120"
Custom sizes	24", 30", 48", or 60" x up to 144"

For added convenience, Falconboard is packed in standard shipping cartons, offering enhanced protection for the product while in transit and provide the user with a compact, easy-to-store container. The standard shipping carton is 6-inches deep and will accommodate a varying number of sheets depending on the thickness of the Falconboard that it contains.

Pregis Hexacomb is the longest standing manufacturer and industry leader in honeycomb production. The only honeycomb provider with an international footprint, our experience, focus on innovation and world-class testing capabilities provide our customers with unique and custom solutions designed to maximize value.

Contact Pregis protective packaging solutions:
877.692.6163
www.pregis.com

©2008 Pregis Corporation. All rights Reserved.



D200HEX 20M 05/09